



Lauderhill Transportation Master Plan

Stakeholder Meeting: **Broward County**
Project Introduction

Agenda

1. Lauderdale TMP: Basic Information

- Agency Introductions
- TMP Purpose
- TMP Schedule
 - (Re) Validation of City Transportation Plan
 - Current Status

2. About Lauderdale

- Youthful City
- City of Elders
- Other Notable Information
- Lauderdale TMP Vision
- Roadway Jurisdiction

3. Discussion

- Planned Improvements and Studies
- (Re) Validation

4. Next Steps



Introductions

MPO Staff:

- Karen Friedman, Senior Planner (TMP Project Manager)
 - FriedmanK@Browardmpo.org
- Andrew Riddle, Community Planning Manager
 - RiddleA@browardmpo.org



Karen Friedman
Senior Planner



Andrew Riddle
Community
Planning Manager

Technical Assistance for TMP: Purpose

Identify *multimodal* projects based on planning principles:

- ✓ Reflect best practices
- ✓ Demonstrated community support
- ✓ **Productive collaboration with facility owners**
- ✓ Well-defined scopes of work
- ✓ Defensible cost estimates
- ✓ Align with federal / state / local priorities
- ✓ Improve safety, mobility, and accessibility for *all roadway users, especially vulnerable users*

TMP *multimodal* project categories:

- Pedestrian facilities / amenities
- Bicycle facilities / amenities
- Transit facilities / amenities
- Safety improvements
- Traffic calming facilities
- Landscaping and resilience facilities

The TMP is *not* intended to:

- Manage roadway congestion
- Assess projects of a scale or complexity that would require a feasibility study

Putting the right street in the right place.

WHAT IS FDOT'S APPROACH TO COMPLETE STREETS?

In September 2014, the Florida Department of Transportation (FDOT) adopted the Statewide Complete Streets Policy (Topic No. 000-625-017-a). Complete Streets serve the transportation needs of transportation system users of all ages and abilities, including pedestrians, bicyclists, transit riders, motorists, and freight handlers. A transportation system based on Complete Streets principles can help to promote safety, quality of life, and economic development.

U.S. Department of Transportation
Federal Highway Administration

OFFICE OF SAFETY
Proven Safety Countermeasures

SPEED MANAGEMENT

- Speed Safety Cameras
- Variable Speed Limits
- Appropriate Speed Limits for All Road Users

ROADWAY DEPARTURE

- Wider Edge Lines
- Enhanced Delineation for Horizontal Curves
- Longitudinal Rumble Strips and Stripes on Two-Lane Roads
- SafetyEdge™
- Roadside Design Improvements at Curves
- Median Barriers

INTERSECTIONS

- Backplates with Retroreflective Borders
- Corridor Access Management
- Dedicated Left- and Right-Turn Lanes at Intersections
- Reduced Left-Turn Conflict Intersections
- Roundabouts
- Systemic Application of Multiple Low-Cost Countermeasures at Stop-Controlled Intersections
- Yellow Change Intervals

PEDESTRIANS/BICYCLES

- Crosswalk Visibility Enhancements
- Bicycle Lanes
- Rectangular Rapid Flashing Beacons (RRFB)

Lauderhill TMP: Schedule

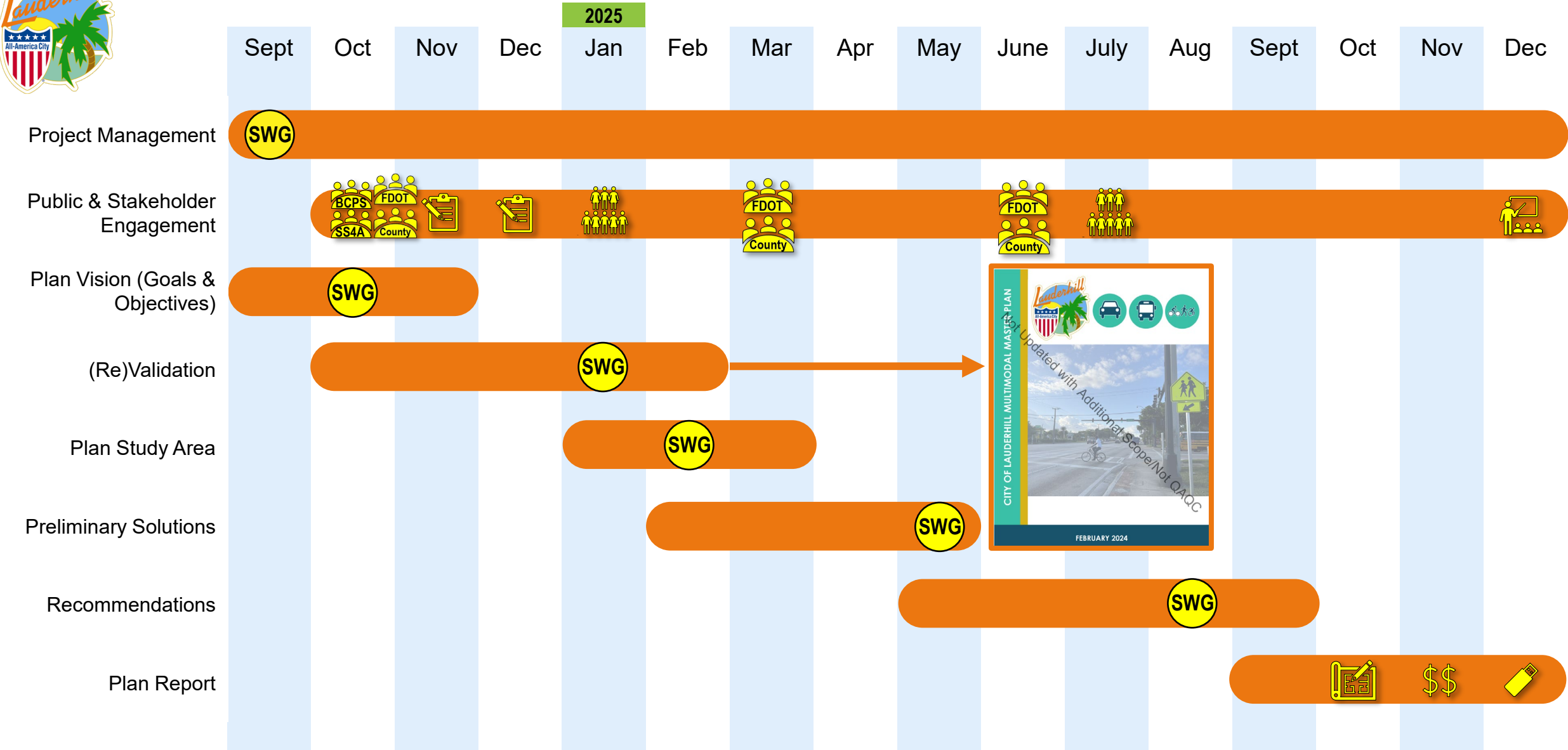

(Re)Validation / General Reflections



NW Plan:

- Completed June 2021
- Study Area: Commercial Blvd to Oakland Pk Blvd; Rock Island Rd to Pine Island Rd
- 8 Study Roadways
- 11 Study Intersections



Citywide Plan:

- Completed Feb. 2024
- Study Area: Commercial Blvd to Oakland Pk Blvd; Rock Island Rd to Pine Island Rd
- 14 Study Roadways
- 9 Study Intersections
- 4 Network Enhancements

Overview of Recommendations

- **Recommendations to address vehicular delay**
 - Extending left and right turn lanes
 - Signal timing optimization
 - Addition of new turn lanes, including double left turn lanes
 - Addition of acceleration lanes
 - Eliminating no right turn on red
- **Recommendations to address pedestrian travel**
 - Sidewalk gap closure
 - New multi-use paths
- **Recommendations to address pedestrian crossings**
 - Addition of pedestrian countdown signals
 - ADA improvements (adding detectable warnings)
 - Upgrade of crosswalks to high visibility
- **Recommendations to address bike travel**
 - Addition of standard bike lanes (in one location)
 - New multi-use paths
- **Recommendations to address transit**
 - Bus route extension
 - Installation of shelters or benches
 - Removal of one transit stop

Summary of Recommendations

- Recommendations are not considered in relation to each other. For example, how does the addition of a double left turn lane or right turn permissive phase impact people walking?
- Recommendations do not seem to address crash history, especially as related to walking and biking crashes.
- Generally the recommendations are vehicle focused.
- Additional bus stop recommendations likely to be carried forward but may change based on further study.
- Limited discussion of pedestrian crossing enhancements other than high emphasis crosswalks.
- Limited discussion of bike facilities at intersections.
- No discussion of bike level of stress; bike recommendations likely not all ages and abilities.
- No discussion of crossing needs outside of currently signalized intersections.
- No discussion of intersections outside of study network. Should be considered for segments at a minimum.
- Limited discussion of bike facilities in southeastern half of city.

Lauderhill TMP: Schedule – Current Status

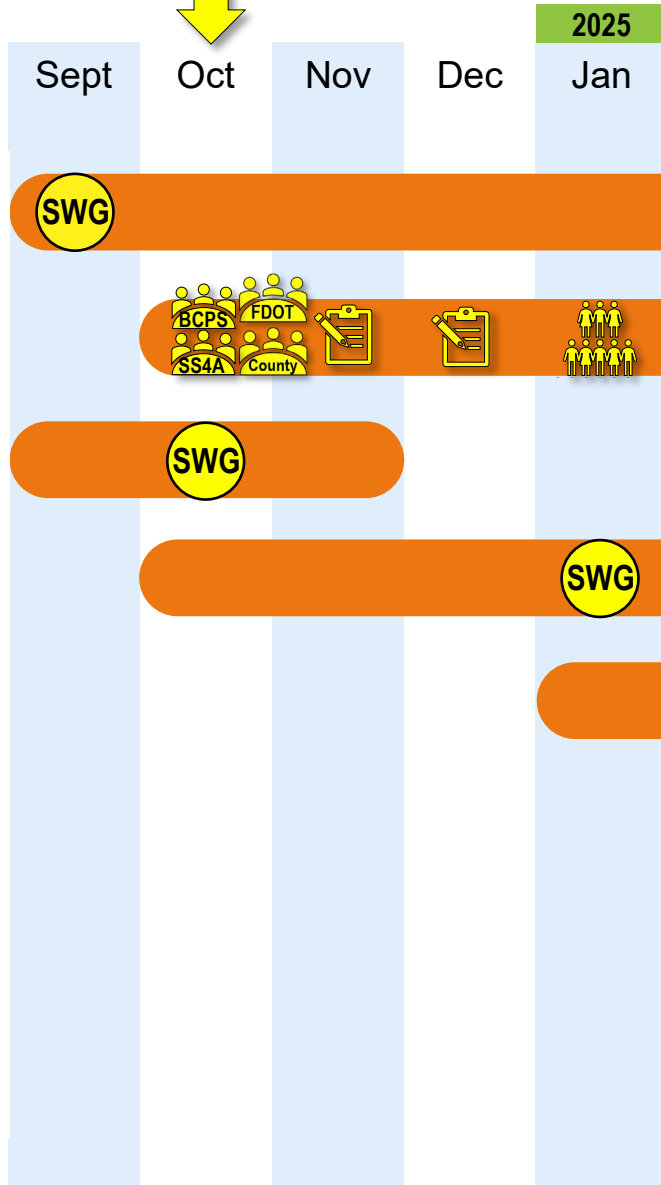

- Oct. 10 – SurveyMonkey live
- Oct. 24 – City SWG Meeting #2 (TMP Vision)
- Oct. 24 – Safe Streets For All NW 31st Ave. Icon Map meeting
- Oct. 24 – Safe Streets For All NW 19th St. Icon Map meeting
- Oct. 29 – Broward Schools Facility Planning Director meeting
- Oct. 31 – Broward County Staff (including BCT) meeting
- Oct. 31 – FDOT Staff (including Turnpike) meeting





The City of **Lauderhill**

Transportation
Master Plan

We want to hear from YOU.

Please complete a Survey before December 15, 2024

www.surveymonkey.com/r/Lauderhill-TMP

About Lauderhill.....

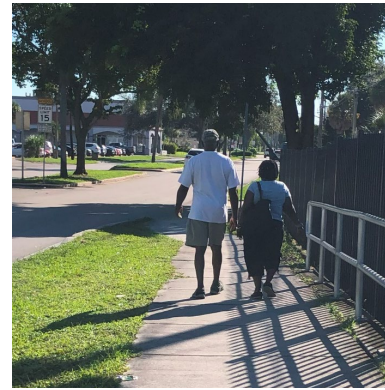

Lauderhill TMP: Youthful City

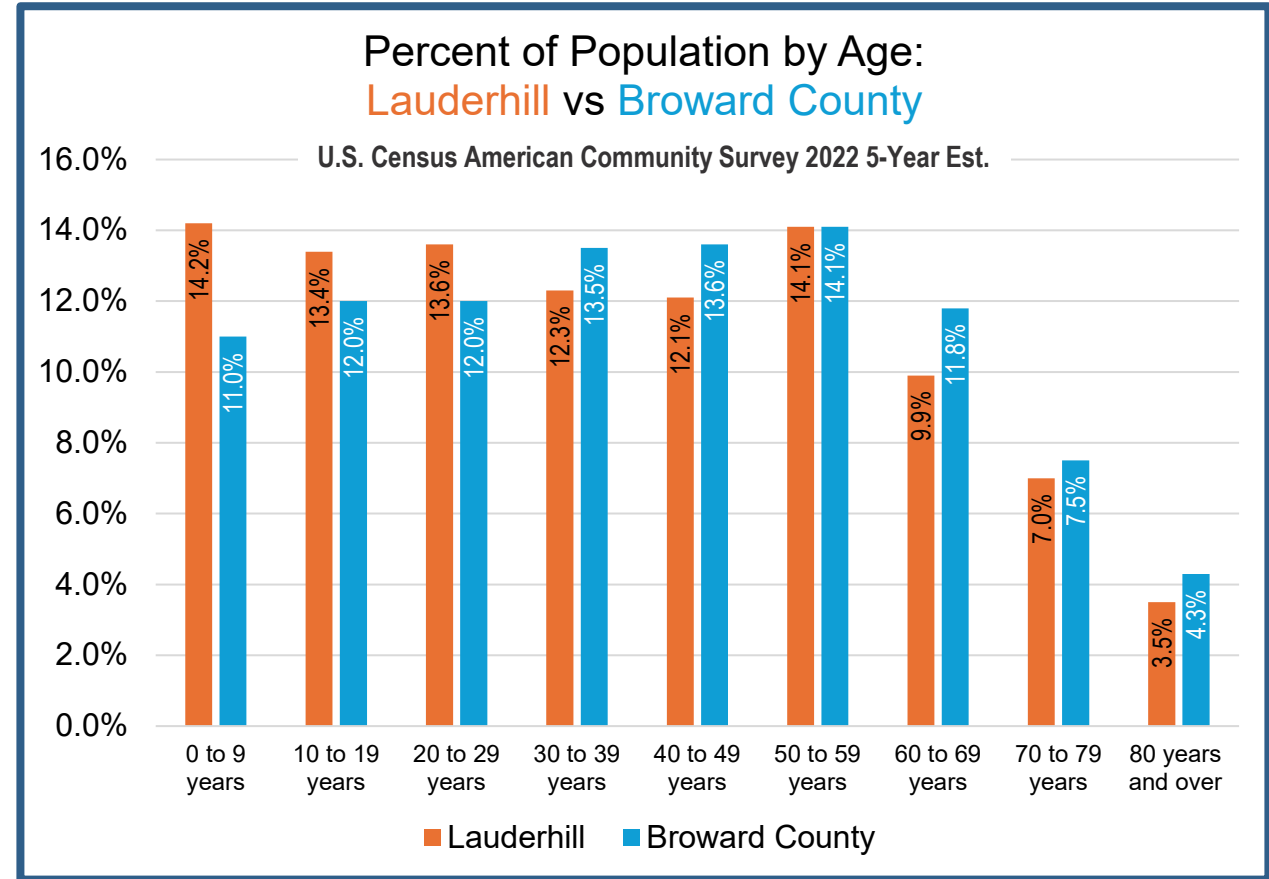
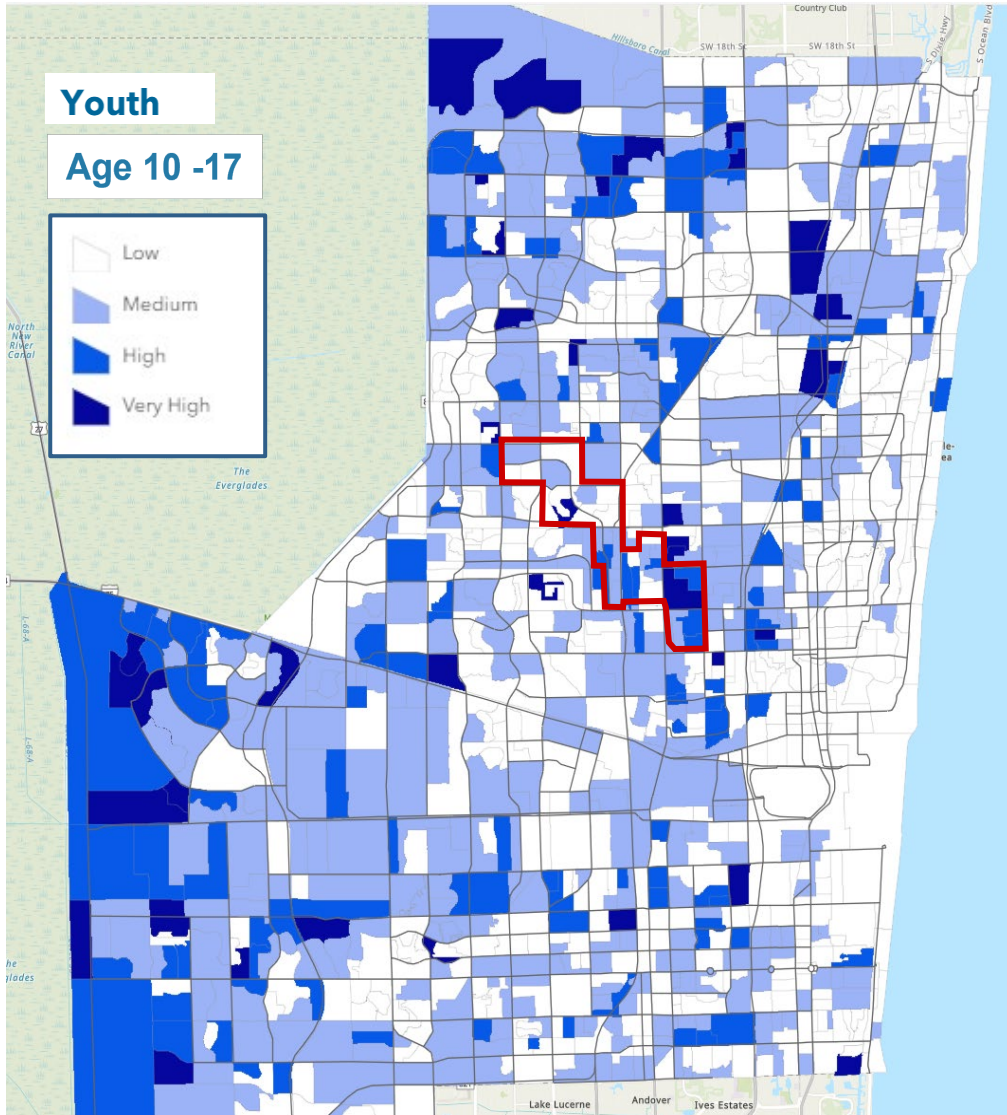

Median Age in Lauderhill compared to Broward County

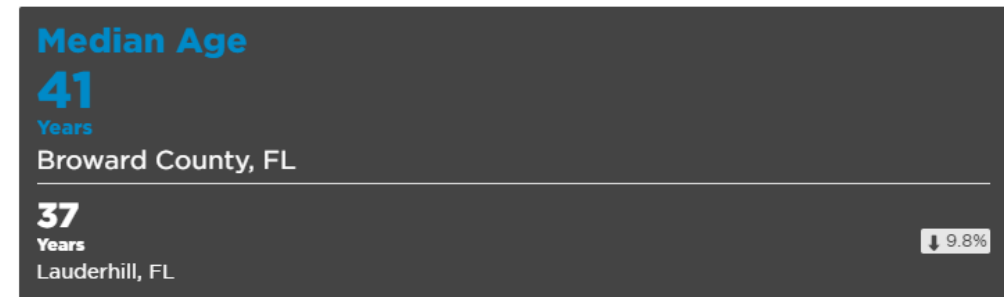

*% Diff. shows the percentage increase or decrease as compared to the original geography.

Sources: US Census ACS 5-year

These concentration “scores” are derived from data obtained from the U.S. Census American Community Survey 2022 5-Year Estimates. These scores illustrate the concentration of the selected indicators within a census block group relative to the county as a whole.

Lauderhill TMP: City for Elders

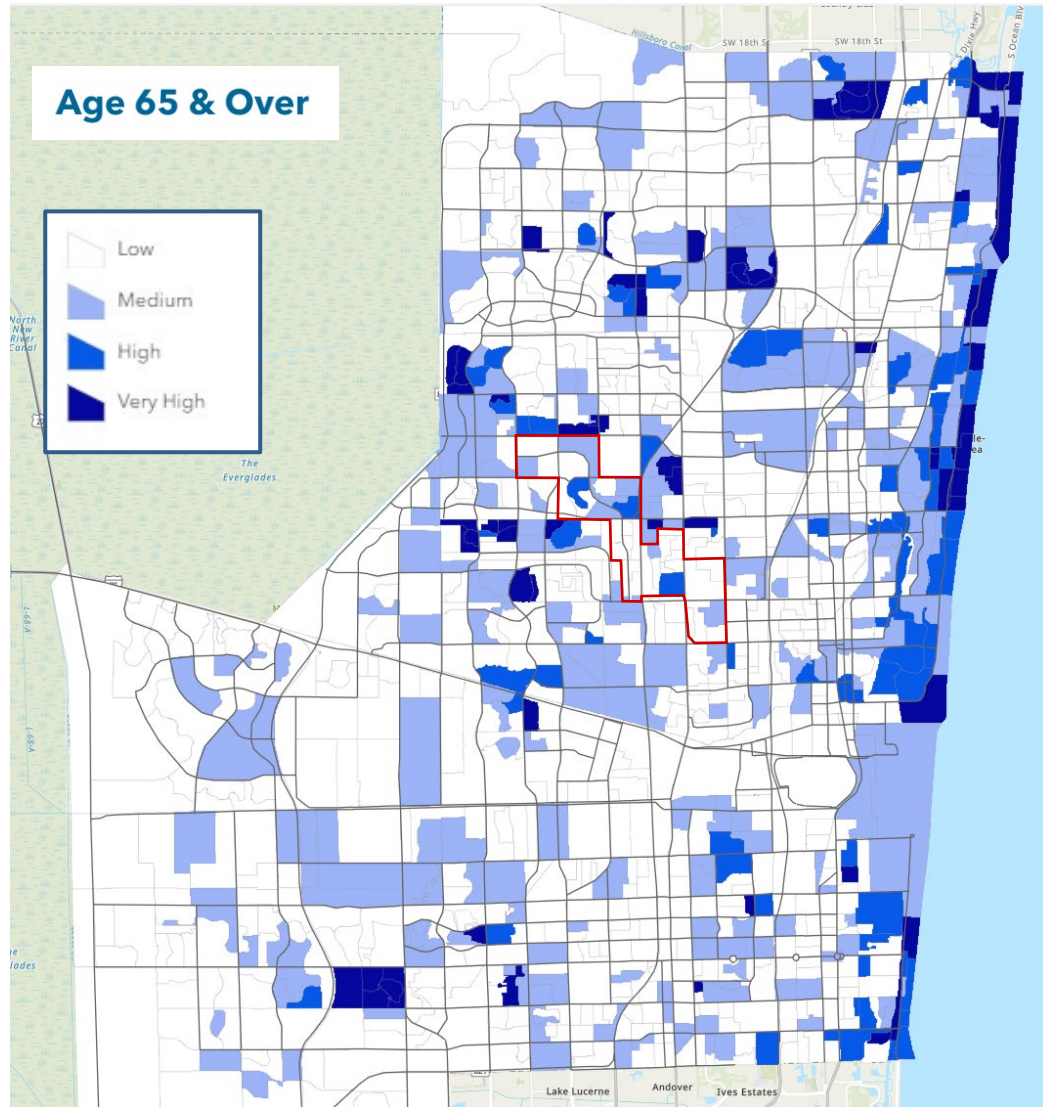

These concentration “scores” are derived from data obtained from the U.S. Census American Community Survey 2022 5-Year Estimates. These scores illustrate the concentration of the selected indicators within a census block group relative to the county as a whole.

Properties for sale in 55+ communities (10/5/2024) – Realtor.com

Sadkin Community Center

Senior Center Program

The Sadkin Senior Center Program provides daily activities like Arts & Crafts Projects, Educational and Health Seminars, Bingo, Travel Trips, Dominoes Club, Fitness Classes, and many other activities that are rewarding and beneficial to our senior community.

Broward Meals on Wheels provides daily nutritious hot meals Monday thru Thursday from 11:30am to 12:15pm.

Monday thru Thursday (except City Holidays)
Senior Center Program
 8:00am to 1:00pm
Dominoes Club
 1:00pm to 8:00pm

Open to Seniors age 55 and above

Participants must have a senior program membership ID card to participate in the activities offered at the Sadkin Senior Center.

Lauderhill residents
\$5.00/per year

Non-residents
\$25.00/per year

Sadkin Community Center
 1176 NW 42nd Way
 Lauderdale, FL 33313

For more information, please call 954-321-2450.

www.lauderhill-fl.gov

Lauderhill TMP: Other Notable Numbers

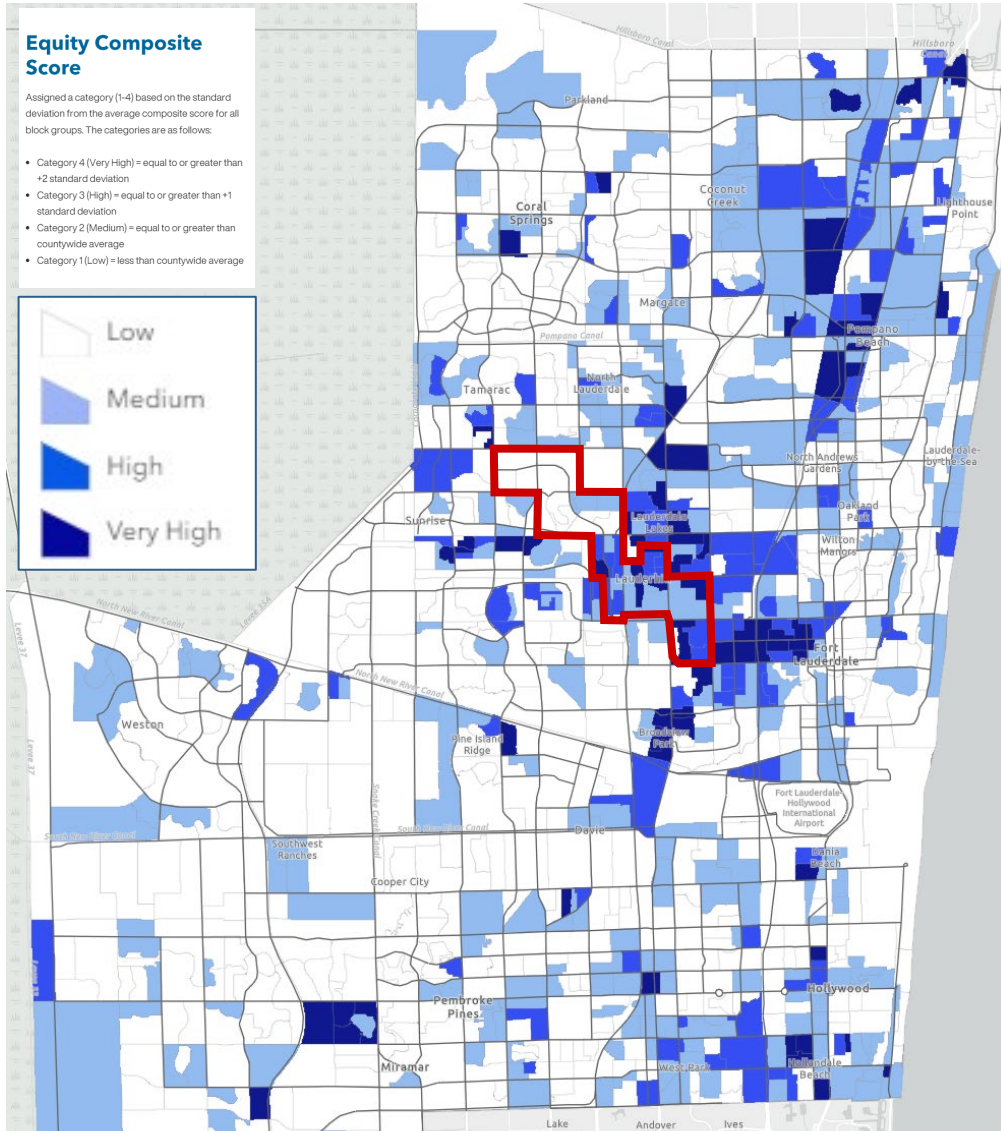

These concentration “scores” are derived from data obtained from the U.S. Census American Community Survey 2022 5-Year Estimates. These scores illustrate the concentration of the selected indicators within a census block group relative to the county as a whole.

- 7 Community Shuttle Routes
- 2 Hassidic synagogues at Inverrary Dr & NW 44 St
- 9 Broward Public Schools:

	In City	Boundary Zones
Elementary	7	12
Middle	2	5
High	1	4

- 2 Libraries
- 26 Parks & Community Centers
- Travel Trends (City vs County)

■ Lauderhill, FL ■ Broward County, FL

Mode of Travel to Work

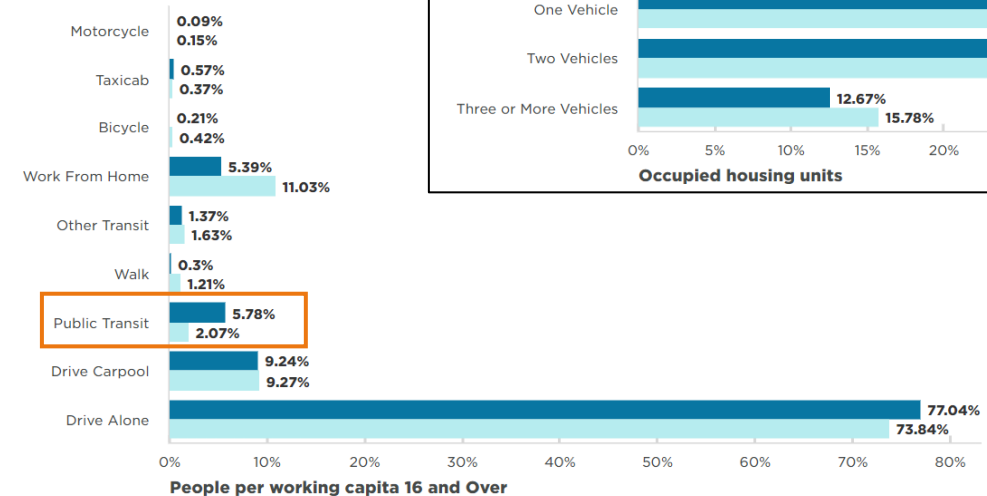

Vehicles Available Per Occupied Housing Unit

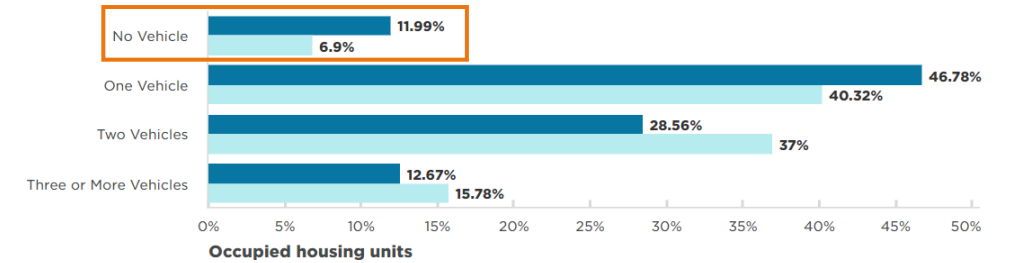

Lauderhill TMP: Roadway Jurisdiction

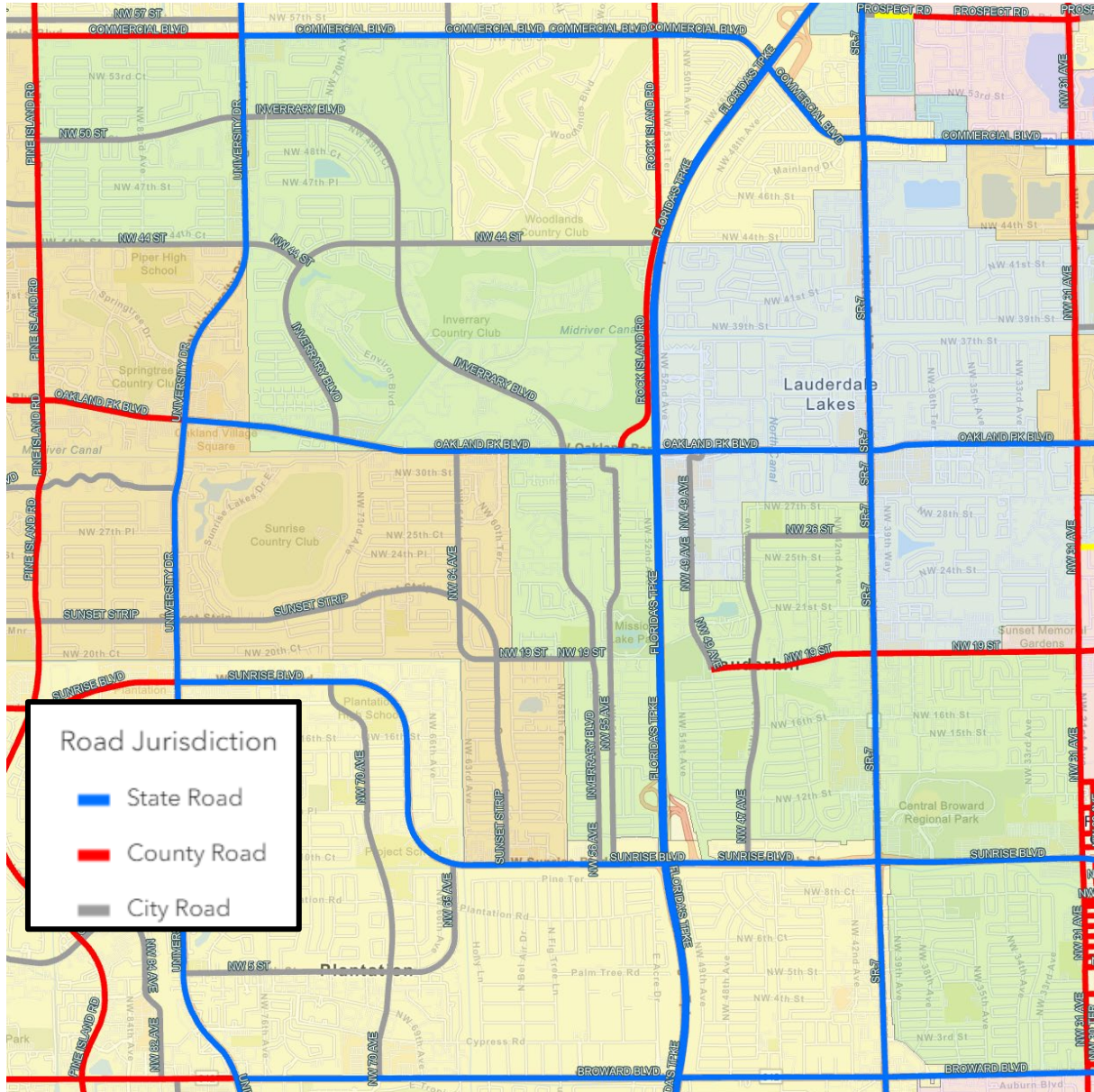

RESOLUTION NO. 93-117

A RESOLUTION APPROVING THE TRAFFIC ENGINEERING AGREEMENT BETWEEN BROWARD COUNTY AND THE CITY OF LAUDERHILL WHEREBY BROWARD COUNTY AGREES TO PERFORM TRAFFIC ENGINEERING FUNCTIONS FOR THE CITY OF LAUDERHILL.

BE IT RESOLVED BY THE COMMISSION OF THE CITY OF LAUDERHILL, FLORIDA:

Section 1. The Traffic Engineering Agreement between Broward County and the City of Lauderhill, a copy of which is attached hereto, is approved and ratified.

Section 2. The Mayor and all appropriate City officials are authorized to execute this Agreement and any other documents which may be required to fulfill the terms of this Resolution.

Section 3. The amendments to Article 4 and Article 14 as set forth in the letter from John P. Clement to Richard R. Smith dated September 1, 1993 shall be made part of the Agreement.

Section 4. This resolution shall take effect immediately upon its passage.

DATED this 13th day of September, 1993.

PASSED AND ADOPTED on first reading this 13th day of September

1993.

[Signature]
PRESIDING OFFICER

ATTEST:
[Signature]
CITY CLERK

[Signature]
MAYOR

Lauderhill TMP: Vision

rooted in the values of family

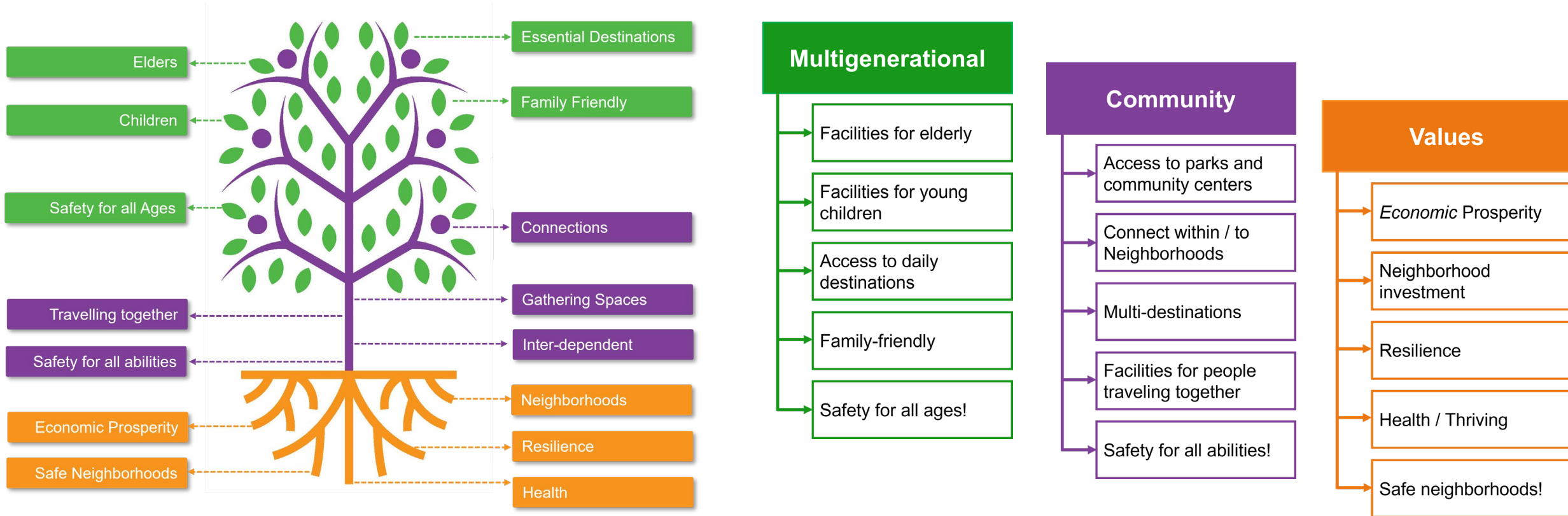

The Vision of the Lauderhill Transportation Master Plan is to ensure the City's transportation system is rooted in the values of family. The TMP is intended to identify improvements that create safe and family-friendly multimodal transportation facilities. The TMP recognizes that the City's transportation facilities have a different but equally important role to play in helping people safely, conveniently, and comfortably get around.

Discussion

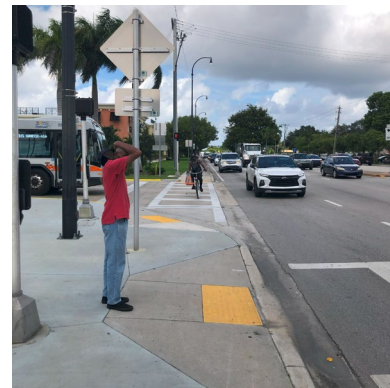
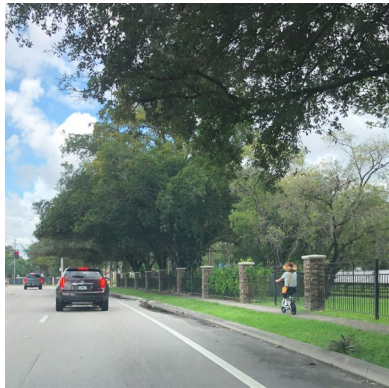

Lauderhill TMP: Planned Improvements / Studies

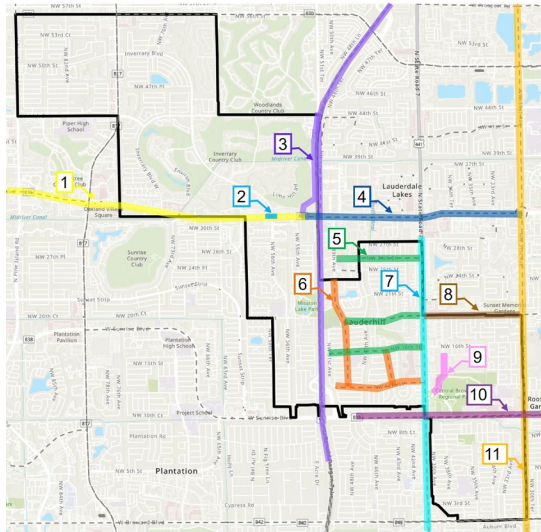

	Roadway	Ownership	Improvement / Study	Status
1	OP Blvd	County & FDOT	PREEMO (BRT)	Planning

PROJECT OVERVIEW:

Project Overview: Connects activity centers between A1A and Sawgrass Mills Mall.

Includes:

- 15 miles of Bus Rapid Transit (BRT) along Oakland Park Boulevard
- Approximately 16 branded stations
- Exclusive transit lanes where feasible
- Supplemental fixed route local service

Anticipated Annual Ridership: 2.4M - 3.2M

Projected Opening: EOY 2028

Estimated Investment: \$226M

Project Overview: Connects activity centers between A1A and Sawgrass Mills Mall. Includes:

- 15 miles of Bus Rapid Transit (BRT) along Oakland Park Boulevard
- Approximately 16 branded stations
- Exclusive transit lanes where feasible
- Supplemental fixed route local service

Anticipated Annual Ridership: 2.4M - 3.2M

Projected Opening: EOY 2028

Estimated Investment: \$226M



• What is the current status?
 • Where is the BRT station location?
 • Is the area near Lauderdale going to be BAT lanes or center-running?

Figure 7-1: Recommended Short Term Improvements



Figure 7-2: BAT Lane with Bus Alternative on Oakland Park Boulevard



Lauderhill TMP: Planned Improvements / Studies

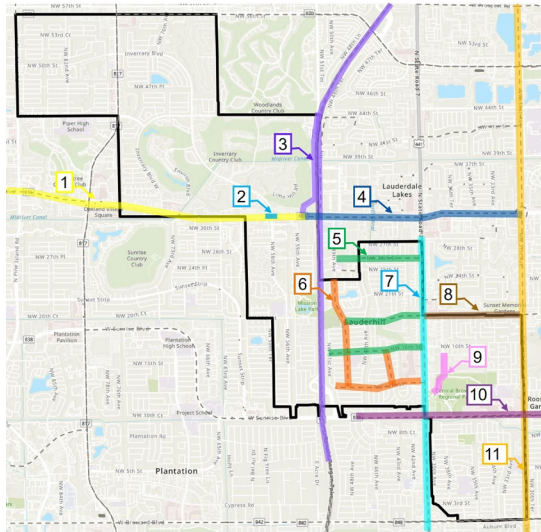

	Roadway	Ownership	Improvement / Study	Status
3	Rock Island Rd & Turnpike	County & FDOT	Rock Island Rd realignment; new Turnpike exchange at Oakland Park Blvd; Turnpike Widening	Design – FY 2029

- What is the current status?
- What multimodal facilities are included for Rock Island Rd?

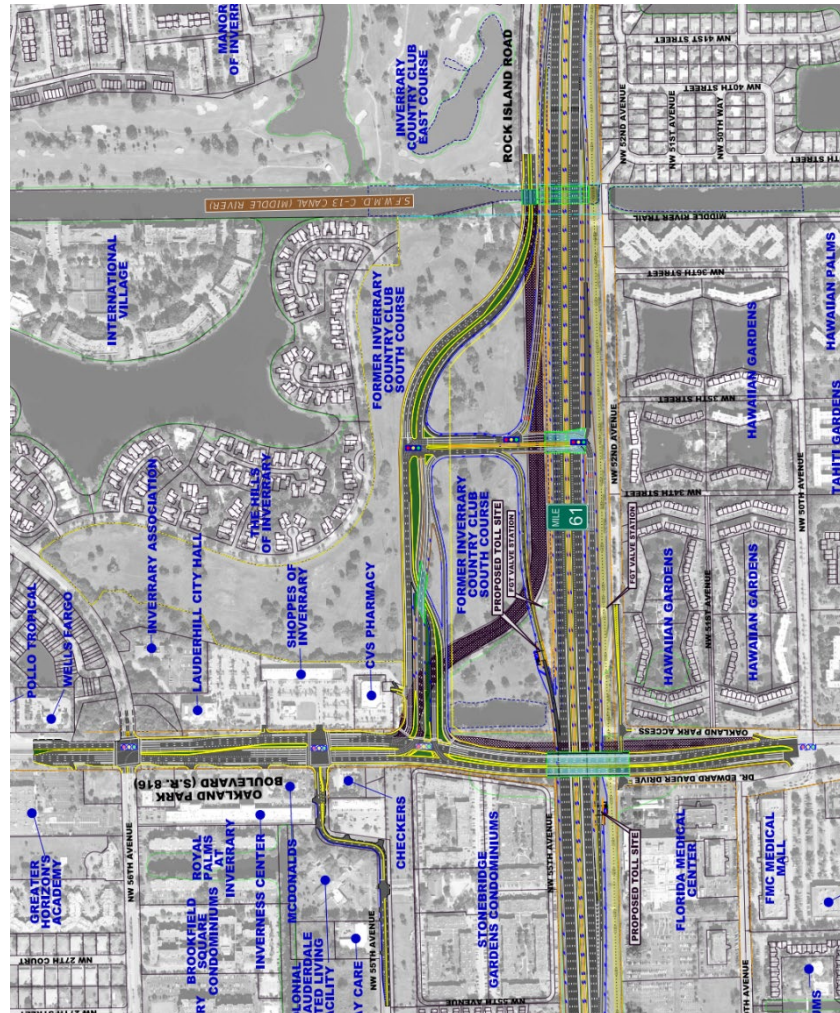
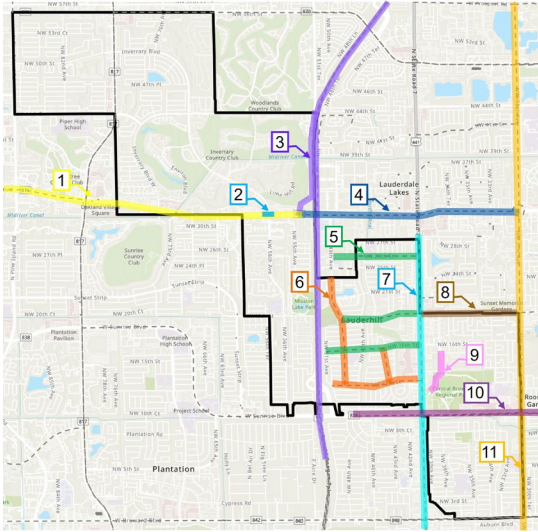

PHOTO RENDERING OF PROPOSED INTERCHANGE LOOKING NORTH



Lauderhill TMP: Planned Improvements / Studies



	Roadway	Ownership	Improvement / Study	Status
8	NW 19 St (441 to NW 31 Av)	County	Broward Safety Action Plan (Study)	Study underway

• Has the County identified funding for design or construction for NW 19 St?

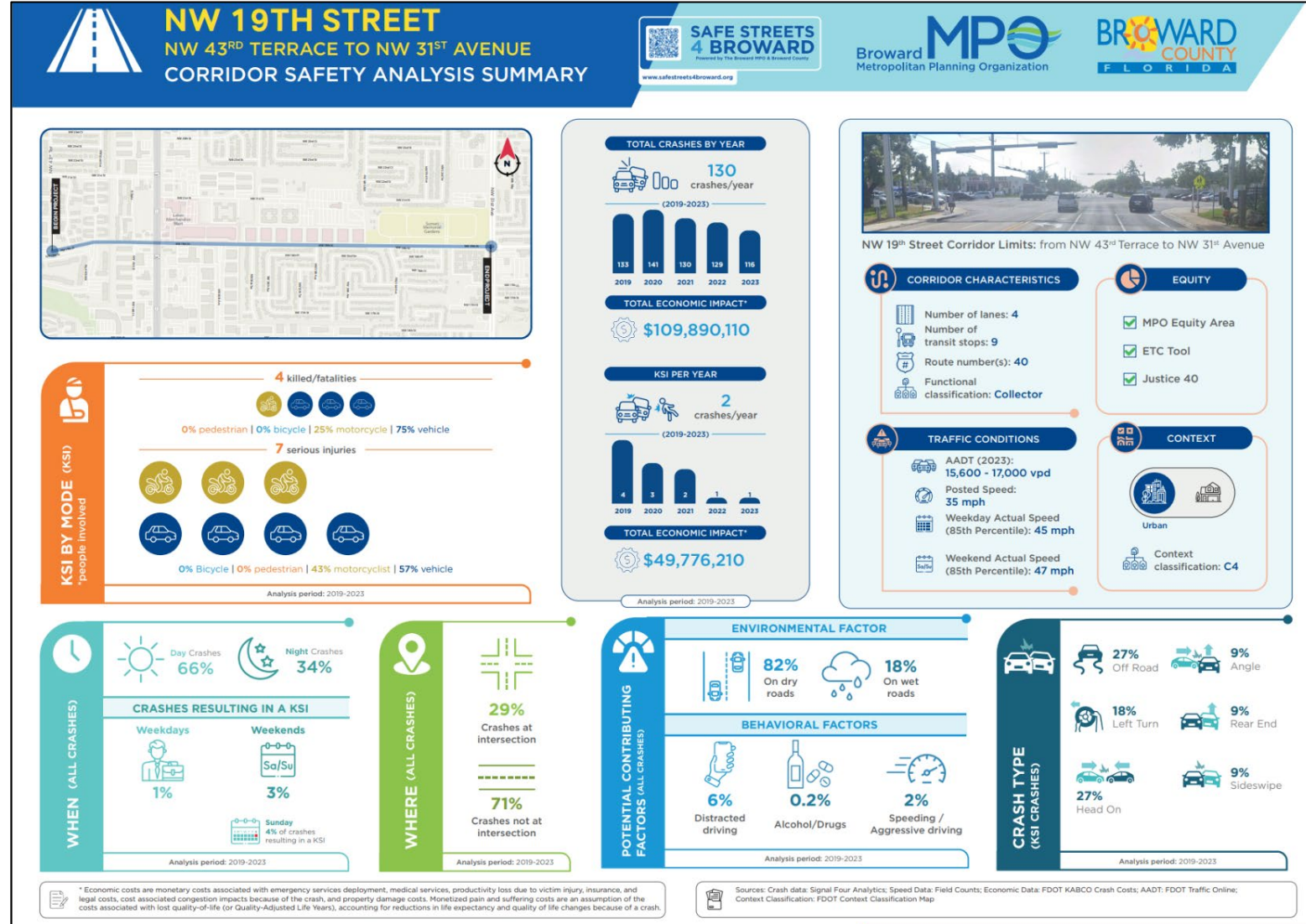

Lauderhill TMP: Planned Improvements / Studies

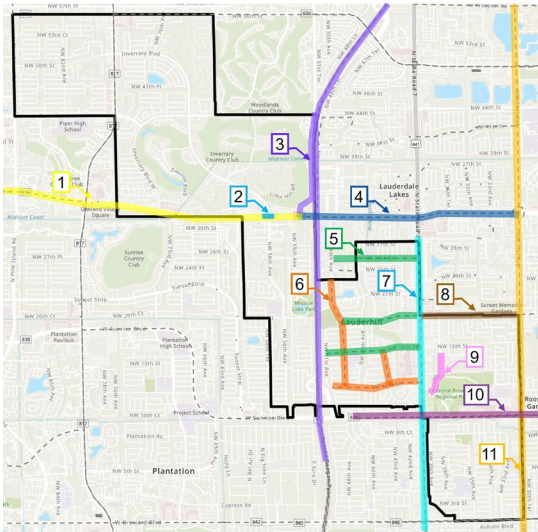

	Roadway	Ownership	Improvement / Study	Status
11	NW 31 Av	County	Bike / Ped Improvements; Broward Safety Action Plan (Study)	Design – 2025 Study Underway

- What is the County's schedule for design?
- Will there be public meetings?

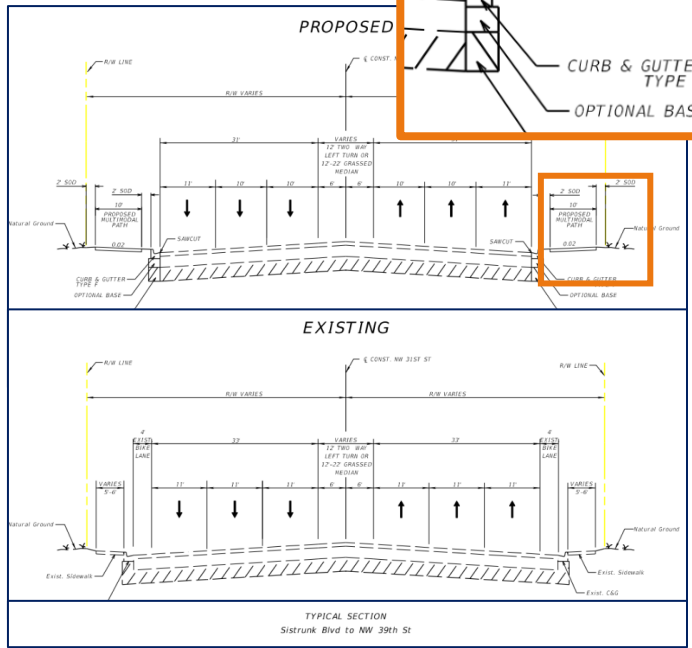
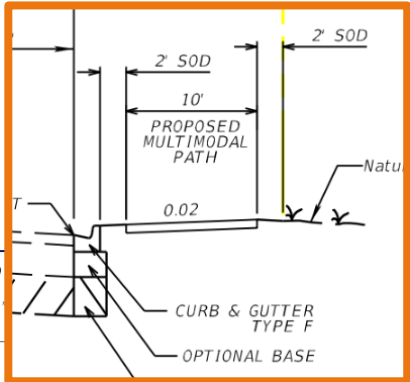

NW 31ST AVENUE

NW 8TH PLACE TO MCNAB ROAD

CORRIDOR SAFETY ANALYSIS SUMMARY

SAFE STREETS 4 BROWARD
Powered by The Broward MPO & Broward County

Broward MPO
Metropolitan Planning Organization

BROWARD COUNTY
FLORIDA

TOTAL CRASHES BY YEAR
(2019-2023)

609 crashes/year

2019: 659 | 2020: 494 | 2021: 603 | 2022: 619 | 2023: 628

TOTAL ECONOMIC IMPACT*
\$ 271,068,270

KSI PER YEAR
(2019-2023)

10 crashes/year

2019: 9 | 2020: 10 | 2021: 8 | 2022: 7 | 2023: 15

TOTAL ECONOMIC IMPACT*
\$ 143,533,170

NW 31st Street Corridor Limits: from NW 8th Place to McNab Road

CORRIDOR CHARACTERISTICS

- Number of lanes: 6
- Number of transit stops: 50
- Route number(s): 31, 40
- Functional classification: Minor Arterial

EQUITY

- MPO Equity Area
- ETC Tool
- Justice 40

TRAFFIC CONDITIONS

- AADT (2023): 26,500 - 45,000 vpd
- Posted Speed: 45 mph
- Weekday Actual Speed (85th Percentile): 52 mph
- Weekend Actual Speed (85th Percentile): 53 mph

CONTEXT

- Urban
- Context classification: C4

KSI BY MODE (KSI)
*people involved

11 killed/fatalities

64% pedestrian | 9% motorcycle | 27% vehicle

37 serious injuries

14% Bicycle | 11% pedestrian | 5% motorcyclist | 70% vehicle

Analysis period: 2019-2023

WHEN (ALL CRASHES)

Day Crashes: 69% | Night Crashes: 31%

CRASHES RESULTING IN A KSI

Weekdays: 1% | Weekends: 2%

Sunday: 3% of crashes resulting in a KSI

Analysis period: 2019-2023

WHERE (ALL CRASHES)

26% Crashes at intersection

74% Crashes not at intersection

Analysis period: 2019-2023

POTENTIAL CONTRIBUTING FACTORS (ALL CRASHES)

- 87% On dry roads
- 13% On wet roads
- 15% Distracted driving
- 1% Alcohol/Drugs
- 2% Speeding / Aggressive driving

Analysis period: 2019-2023

CRASH TYPE (KSI CRASHES)

- 6% Off Road
- 7% Angle
- 22% Left Turn
- 2% Overturn
- 22% Pedestrian
- 14% Rear End
- 6% Bicycle
- 12% Sideswipe

Analysis period: 2019-2023

* Economic costs are monetary costs associated with emergency services deployment, medical services, productivity loss due to victim injury, insurance, and legal costs, cost associated congestion impacts because of the crash, and property damage costs. Monetized pain and suffering costs are an assumption of the costs associated with lost quality-of-life (or Quality-Adjusted Life Years), accounting for reductions in life expectancy and quality of life changes because of a crash.

Sources: Crash data: Signal Four Analytics; Speed Data: Field Counts; Economic Data: FDOT KABCO Crash Costs; AADT: FDOT Traffic Online; Context Classification: FDOT Context Classification Map

NW Plan: Network Recommendations Concepts

Middle River Trail Extension (From Citywide Plan – Network Enhancements)

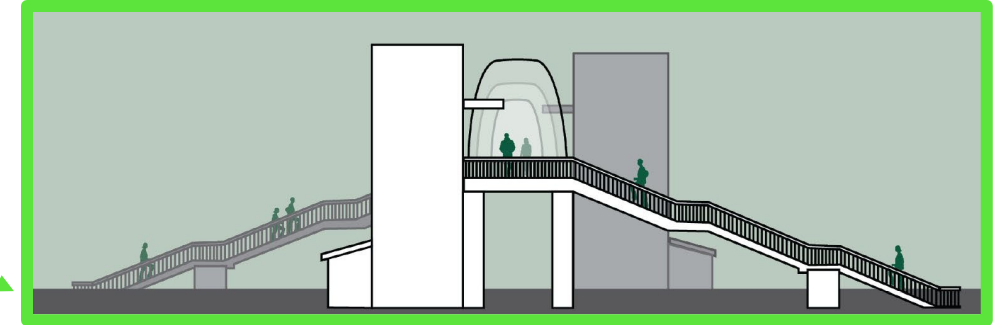

Plan Recommendation: Construct Shared Use Path and pedestrian bridge over turnpike and Inverrary Drive; add crossing enhancements

Comments: Agree with recommendations; may enhance based on existing conditions analysis if appropriate

Citywide Plan: Network Recommendations

Concepts

NW 19th Street Extension

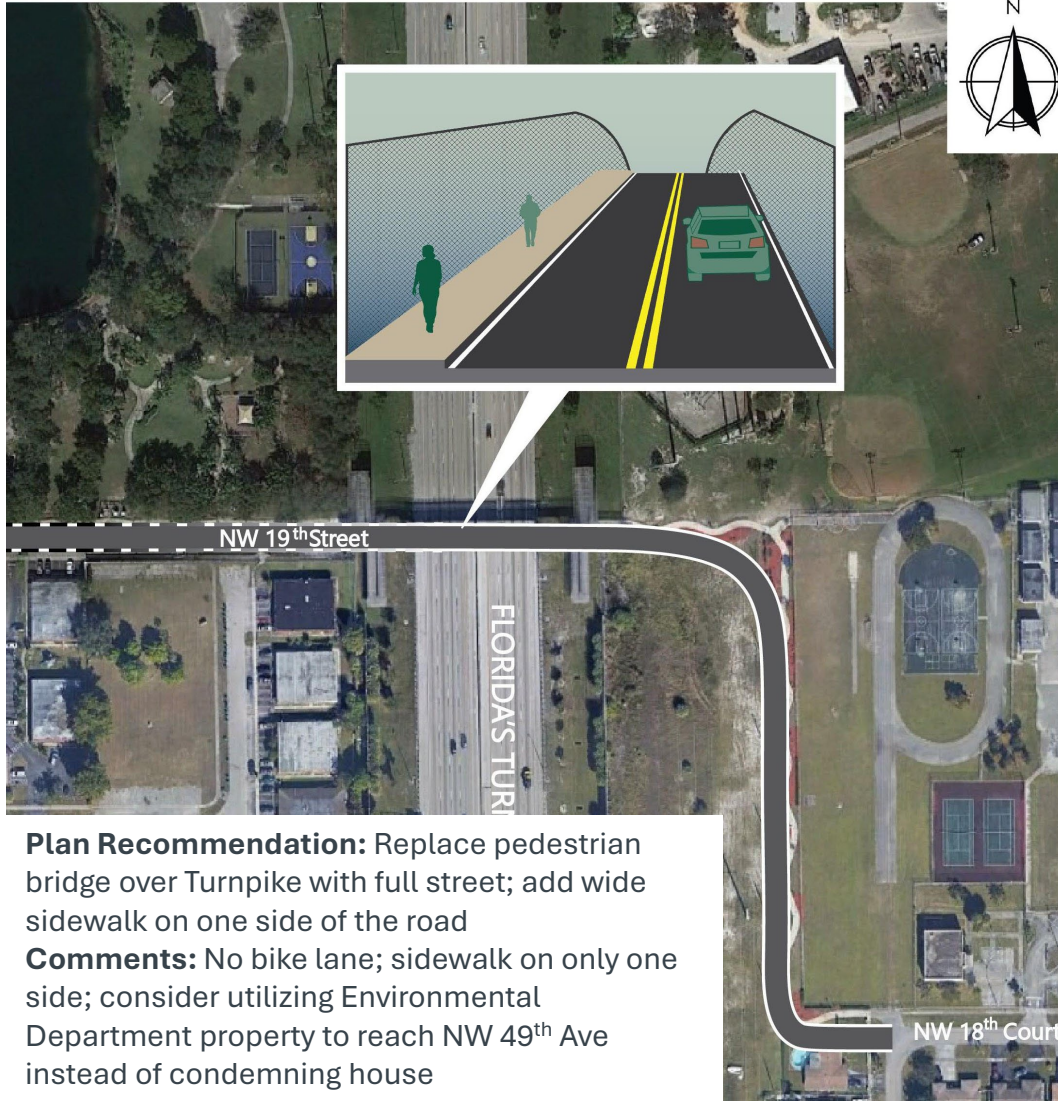

Plan Recommendation: Replace pedestrian bridge over Turnpike with full street; add wide sidewalk on one side of the road

Comments: No bike lane; sidewalk on only one side; consider utilizing Environmental Department property to reach NW 49th Ave instead of condemning house

NW 38th Avenue Pedestrian Bridge



Plan Recommendation: Add pedestrian bridge over Sunrise Blvd

Comments: Unclear if / how people biking will be accommodated

Lauderhill TMP: Next Steps

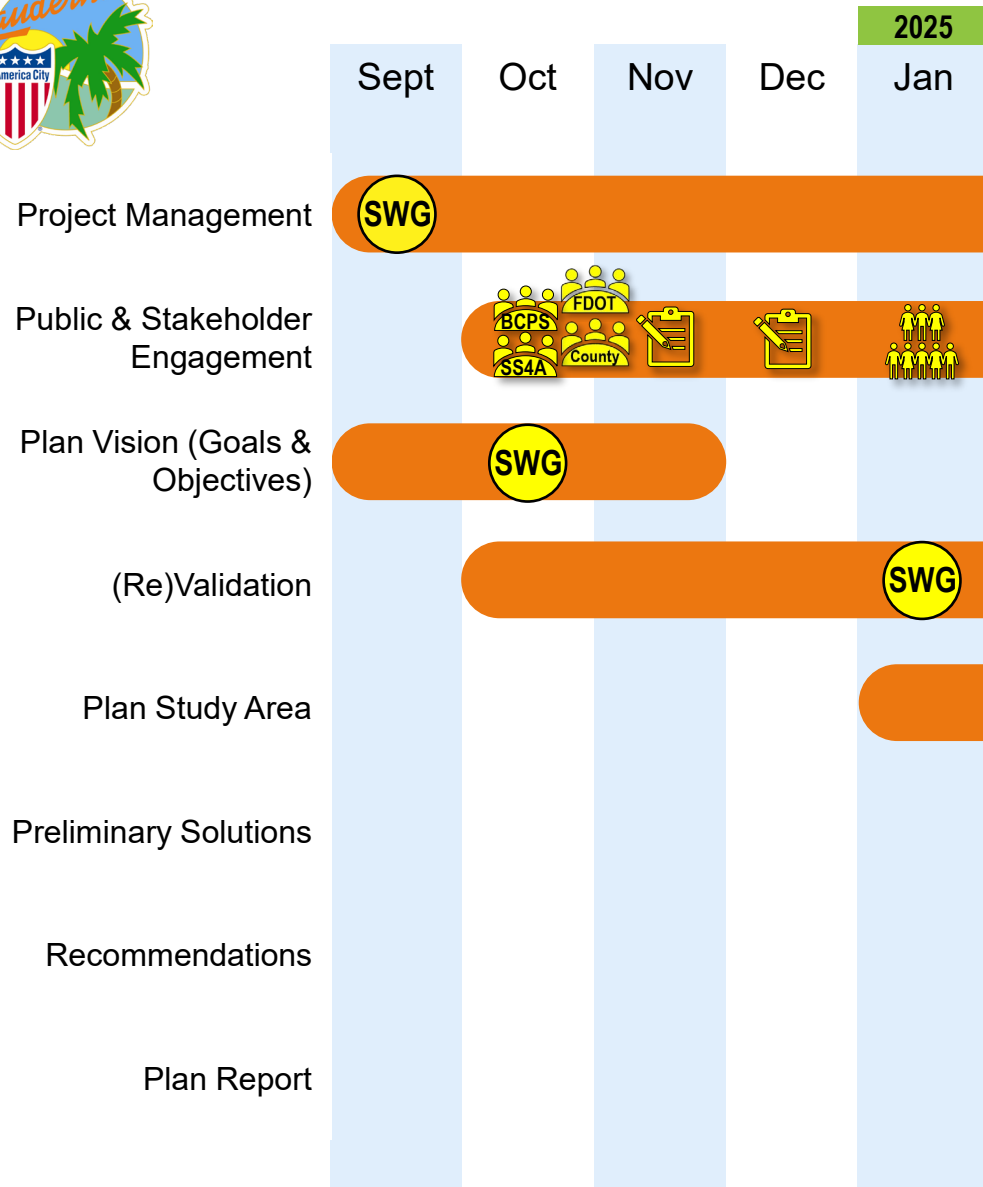

MPO Next Steps

1. Attend Stakeholder meetings: Safe Streets for All, Broward Schools, Broward County, & FDOT
2. Finalize initial Public Engagement Plan (including scheduling January 2025 Community Meetings)
3. Refine Goals and Objectives + Develop TMP Evaluation Framework:
 - Complete (Re) Validation of McMahon Plan Recommendations
 - Prepare Citywide, high level existing conditions assessment
4. Data Collection + Field Visits (Ongoing)
5. Analyze Results of TMP Survey (Survey closes Dec 15th)

Next Steps with Broward County

- Provide feedback on City's NW & Citywide Transportation Plan
- **January 2025** – Invited to TMP Community Meetings
- **March 2025** – Meeting to present Plan Study Area Roadways + Existing Conditions





The City of **Lauderhill**

Transportation Master Plan

We want to hear from YOU.
Please complete a Survey before December 15, 2024

www.surveymonkey.com/r/Lauderhill-TMP

